



ORIGINAL ARTICLE

Measuring intradialyser transmembrane and hydrostatic pressures: pitfalls and relevance in haemodialysis and haemodiafiltration

Alain FICHEUX^{1,2}, Nathalie Gayrard^{1,2}, Ilan Szwarc³, Flore Duranton^{1,2}, Fernando Vetromile³, Philippe Brunet⁴, Marie-Françoise Serval³, Joachim Jankowski⁵ and Àngel Argilés^{1,2,3}

¹RD – Néphrologie, Montpellier, France, ²BC2M, Univ Montpellier, Montpellier, France, ³Centre de dialyse de Sète, Néphrologie Dialyse St Guilhem, Sète, France, ⁴Hôpital de La Conception, Université Aix-Marseille, Service de Néphrologie, Marseille, France and ⁵Institute for Molecular Cardiovascular Research, RWTH Aachen University, Aachen, Germany

Correspondence and offprint requests to: Àngel Argilés; E-mail: argiles@rd-n.org

ABSTRACT

Background. Post-dilutional haemodiafiltration (HDF) with high convection volumes (HCVs) could improve survival. HCV-HDF requires a significant pressure to be applied to the dialyser membrane. The aim of this study was to assess the pressure applied to the dialysers in HCV-HDF, evaluate the influence of transmembrane pressure (TMP) calculation methods on TMP values and check how they relate to the safety limits proposed by guidelines.

Methods. Nine stable dialysis patients were treated with post-dilutional HCV-HDF with three different convection volumes [including haemodialysis (HD)]. The pressures at blood inlet (B_i), blood outlet (B_o) and dialysate outlet (D_o) were continuously recorded. TMP was calculated using two pressures (TMP2: B_o , D_o) or three pressures (TMP3: B_o , D_o , B_i). Dialysis parameters were analysed at the start of the session and at the end of treatment or at the first occurrence of a manual intervention to decrease convection due to TMP alarms.

Results. During HD sessions, TMP2 and TMP3 remained stable. During HCV-HDF, TMP2 remained stable while TMP3 clearly increased. For the same condition, TMP3 could be 3-fold greater than TMP2. This shows that the TMP limit of 300 mmHg as recommended by guidelines could have different effects according to the TMP calculation method. In HCV-HDF, the pressure at the B_i increased over time and exceeded the safety limits of 600 mmHg provided by the manufacturer, even when respecting TMP safety limits.

Conclusions. This study draws our attention to the dangers of using a two-pressure points TMP calculation, particularly when performing HCV-HDF.

Keywords: convection volume, haemodiafiltration, haemodialysis, transmembrane pressure, ultrafiltration

Received: 12.9.2018; Editorial decision: 1.3.2019

© The Author(s) 2019. Published by Oxford University Press on behalf of ERA-EDTA.

This is an Open Access article distributed under the terms of the Creative Commons Attribution Non-Commercial License (<http://creativecommons.org/licenses/by-nc/4.0/>), which permits non-commercial re-use, distribution, and reproduction in any medium, provided the original work is properly cited. For commercial re-use, please contact journals.permissions@oup.com

INTRODUCTION

Haemodiafiltration (HDF) is an extracorporeal renal replacement technique that is based on both diffusion (passage of solutes across a permeable membrane according to a concentration gradient) and convection (passage of a fluid across a permeable membrane according to a pressure gradient). In HDF, convection is obtained by extracting fluid from the closed dialysate circuit at a given flow rate, which is then given back to the blood circuit either before the dialyser (pre-dilutional HDF) or after the dialyser (post-dilutional HDF; Figure 1). Recent evidence from randomized controlled trials suggests that post-dilutional HDF is associated with a benefit in survival, which would only be significant provided it is performed with high convection volumes (HCVs), that is, 17.4L/session for the Turkish study [1–3]. Maduell et al.'s [4] latest study on incident patients confirms this improvement in survival. However, the most recent analysis of the Dialysis Outcomes and Practice Patterns Study (DOPPS) data [5] on a larger number of patients in several European centres does not confirm this benefit. The fact that dialysis conditions and equipment to obtain HCV-HDF vary across DOPPS facilities and are more homogeneous in the Maduell study may explain the discrepancy.

To obtain HCV-HDF, significant pressure has to be applied to the dialyser membrane, frequently surpassing what is known as the $G_{K_{D-UF}}$ max situation of the dialysis systems [6, 7]. $G_{K_{D-UF}}$ stands for Global Coefficient of Ultra Filtration in the presence of Dialysate fluid. This parameter is not constant; it follows a parabolic function when convection is increased. The $G_{K_{D-UF}}$ max is the vertex of this parabola, which corresponds to the situation where the maximum convection volume is obtained with the least applied pressure [transmembrane pressure (TMP)] [6, 7]. Then, when aiming to obtain as high as possible convection volumes [8], the dialysis systems are submitted to significantly stronger TMP constraints. The question arises to whether the resistance of the extracorporeal circuit to pressure is unlimited and what are the regulations warranting the security of the dialysis systems in terms of intra-dialyser pressure. Manufacturers specify the pressure limits of the dialysers in their notice and the European Renal Best Practice (ERBP) guidelines propose a TMP limited to 300 mmHg, as a safe maximum value [9]. However, TMP calculation is not standardized and commercially available monitors differ in their approaches [10]. Some dialysis monitors provide TMP calculated based on two pressure measurements (TMP2), whereas others use, or can use, a calculation based on three pressure measurements (TMP3). When assessing TMP2, pressures are measured at the blood outlet (P_{Bo}) and dialysate outlet (P_{Do}); when assessing TMP3, the measurement at the blood inlet (P_{Bi}) is also considered [10]. In presently available guidelines, there is no mention of how TMP should be measured and whether the value retained as a limitation applies to the mean observed pressure in the dialyser or the maximum pressure at any point of it [9]. Data on the influence of the two- or three-point (taking into account the pressure at the B_i) measurements on TMP are lacking and the actual values of pressure in the different points of the dialyser are not usually considered by clinicians when performing dialysis treatment.

The present work aimed to evaluate the influence of the calculation of TMP (2 and 3 point) on its absolute value in the clinical situation of post-dilutional HDF with different convection volumes. This study focuses on the intra-dialyser pressures in real haemodialysis (HD) and online post-dilution HDF treatments. It analyses the data obtained from a larger study for

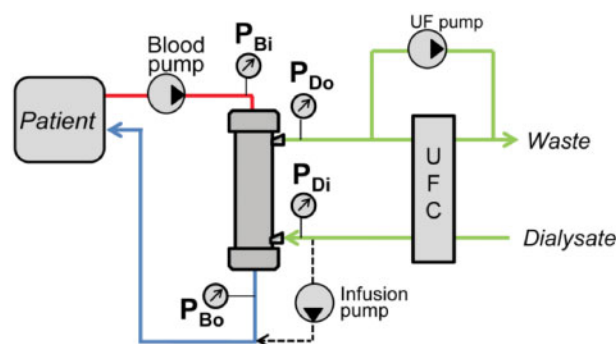

Estimating TMP from 2, 3 and 4 points:

- (1) $TMP2 = P_{Bo} - P_{Do}$
- (2) $TMP3 = ((P_{Bi} + P_{Bo})/2) - P_{Do}$
- (3) $TMP4 = ((P_{Bi} + P_{Bo})/2) - ((P_{Di} + P_{Do})/2)$

FIGURE 1: Schematic extracorporeal circuit displaying the measurement points and the resulting TMP calculations. The formulas for TMP2, TMP3 and TMP4 are displayed.

which technical and clinical aspects have been previously published [11, 12]. In these reports, the sensitivity and reliability of determining $G_{K_{D-UF}}$ max were demonstrated to be in the range of clinical use [11], and its application in clinics showed to be beneficial as it rendered the extracorporeal circuit more stable in terms of pressure constraints and decreased the number of alarms during treatments while allowing to reach sensibly HCVs [12].

MATERIALS AND METHODS

Preliminary study

By definition, TMP measurement requires the determination of four parameters: pressure at the blood line inlet (P_{Bi}), at the blood line outlet (P_{Bo}), at the dialysate outlet (P_{Do}) and at the dialysate inlet (P_{Di}) of the dialyser. In the clinical setting, P_{Di} is usually unavailable, but some dialysis generators include this parameter such as the DBB-05 generators (Nikkiso, Tokyo, Japan). We analysed data from four patients dialysed on Nikkiso DBB-05 generators with 1.8 m² HF80 dialysers (Fresenius Medical Care, Bad Homburg, Germany), in post-dilutional HDF. We applied step increases in convection flow [cumulative 10 mL/min increases in the flow rate of the infusion pump (Figure 1)] and recorded the four pressures at the dialysate and B_i and outlet displayed on the generator when reaching the programmed convection at every step. We calculated and compared the resulting TMP2, TMP3 and TMP4 (formulas in Figure 1).

Clinical study

Patients. The population under study is described in Table 1. Nine dialysis patients stable at the moment of the study were assessed. There were four men and five women and mean age was 73 ± 4 years. Their dialysis accesses were arterio-venous fistulae ($n=8$) and tunnelled jugular catheter ($n=1$). All patients gave their written informed consent. The study protocol was approved by the 'Comité de Protection des Personnes' of Nîmes (2011.10.05 bis) with the registration number at the French Agency AFSSAPS 2011-A01092-39. The study was performed in agreement with the declaration of Helsinki.

Dialysis modality. Patients were treated with post-dilutional HDF with 1.8 m² Amembris membrane dialysers (B BRAUN Avitum, Melsungen, Germany) with three different levels of convection, each applied during three consecutive treatments (total 81 sessions). The convection volumes were: (i) HD (convection volume limited to the weight loss); (ii) post-dilutional HDF with the convection flow corresponding to the maximum of the ultrafiltration flow-to-TMP ratio (HCV-HDF at $_{gK_{D-UF}} \max$) [11]; and (iii) post-dilutional HDF with the highest acceptable convection flow (HCV-HDF at $_{Q_{UF}} \max$). Safety alarms were set according to the recommendations of the ERBP guidelines: ultrafiltration rate limited to 30% of the blood flow and TMP3 was limited to 300 mmHg [9]. No automatic system adapting convection was utilized. The nursing staff had the prerogative of modifying the infusion flow if TMP alarms prevented from pursuing the dialysis at the prescribed convection volumes. Blood flow, convection volumes and dialysis times are summarized in Table 2.

Variables measured and TMP calculations. HDF machines with three pressure sensors (Dialog+, B BRAUN Avitum, Melsungen, Germany) were used. The pressures P_{Bi} , P_{Bo} and P_{Do} of the dialyser (Figure 1) were continuously recorded by the dialysis monitor. Two time points of the dialysis session were specifically studied: (i) at the beginning of the treatment (T_{start}) and (ii) at the end of dialysis session or when TMP alarms induced a manual intervention to decrease convection ($T_{end \text{ or } modif}$). The average of 10 consecutive readings per patient and time point was considered. TMP was calculated using two pressure points (TMP2) and three pressure points (TMP3) according to formulas displayed in Figure 1.

Statistical analysis

Differences between dialysis conditions were analysed by variance analysis (ANOVA) accounting for the cross-over design. Post hoc tests were performed, adjusting for multiple comparisons using the Bonferroni correction. Statistical analyses were

Table 1. Patients characteristics

Characteristics	Patients (n = 9)
Gender	5F/4M
Age (years)	73 ± 4
Body weight after dialysis (kg)	68 ± 5
Haematocrit (%)	35.7 ± 1.5
Serum proteins (g/L)	62.6 ± 1.5
Serum albumin (g/L)	36.0 ± 1.2

Table 2. Observed characteristics of different dialysis conditions

Dialysis condition	HD	$_{Q_{UF}} \text{ at } _{gK_{D-UF}} \max$	$_{Q_{UF}} \max$	P-value
Number of sessions	26	27	26	–
Session duration (min)	234 ± 3	237 ± 3	236 ± 4	0.51
Blood flow (mL/min)	362 ± 7	360 ± 7	365 ± 6	0.50
Dialysate flow (mL/min)	601 ± 2	601 ± 1	601 ± 1	0.38
Ultrafiltration volume for weight loss (L)	2.6 ± 0.2	2.8 ± 0.2	2.9 ± 0.2	0.74
Ultrafiltration volume for infusion (L)	0	17.8 ± 0.3	22.2 ± 0.5	<0.001*
Total ultrafiltration volume (L)	2.6 ± 0.2	20.6 ± 0.4	25.1 ± 1.0	<0.001*
Total ultrafiltration flow over blood flow (%)	3.0 ± 0.2	24.0 ± 0.3	28.7 ± 0.3	<0.001*

*All adjusted P-values for pairwise comparisons <0.001.

performed using SAS version 9.4 (SAS Institute, Cary, NC, USA). Tests were performed using a Type I error of 5%. Results are given as the mean ± standard error of the mean.

RESULTS

Influence of TMP calculation and convection flow on TMP value

In a preliminary study, the influence of using 2, 3 and 4 point measurements on TMP value was assessed at different levels of convection. Figure 2 shows an illustrative example of the pressure values and resulting TMP obtained, whereas the dialysis system was submitted to a full range of convection. These results, presented for one case, were reproduced in all participating patients. In Figure 2A, it can be observed that P_{Bi} increases exponentially with convection flow, while P_{Bo} remained constant. The dialysate pressures P_{Di} and P_{Do} decrease exponentially with the increase in $_{Q_{UF}}$, in a near parallel way mirroring changes in P_{Bi} .

The TMP values calculated from the 2, 3 or 4 pressure measurements for the same treatment are presented in Figure 2B. It can be observed that TMP2 underestimates TMP3 of 45–140 mmHg. The difference between TMP3 and TMP2 increases with increasing convection flow due to the exponential increase in P_{Bi} , while P_{Bo} remains constant (Figure 2A). The patterns of TMP3 and TMP4 are similar and absolute values differ by around 50 mmHg across the $_{Q_{UF}}$ range (Figure 2C). This value, according to the TMP formulas, is the half of the pressure drop in the dialysate [$(P_{Di} - P_{Do})/2$]. It is around 100 mmHg (Figure 2A), well above the *in vitro* pressure drop measured at sites strictly corresponding to the dialyser length (25 ± 3 mmHg, in agreement with the values given by the manufacturer). The discrepancy can be explained by the position of the P_{Di} sensor in the Nikkiso DBB-05 machine, away from the dialyser inlet. In this setting, the difference between TMP3 and TMP4 is about 12.5 mmHg (half of 25 mmHg) when dialysate pressure sensors are adjacent to the dialyser. It can be concluded that the fourth pressure measurement (P_{Di}) has a minimal influence on TMP estimation.

Intradialyser transmembrane and hydrostatic pressures during treatment

In the clinical study, we collected pressure records every 30 s from three-pressure sensors generators to assess the clinical relevance of different TMP estimations for dialysis session monitoring.

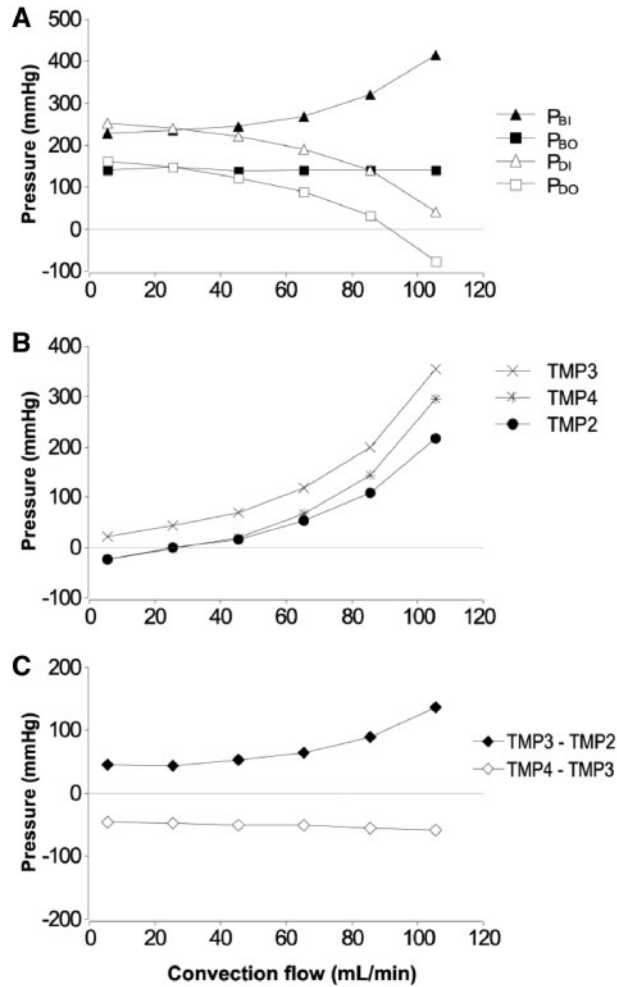

FIGURE 2: Pressure readings over total ultrafiltration flow variation in a dialysis system equipped with four pressure sensors. (A) The recorded values at the dialyser inlet and outlet at the blood compartment lines (P_{Bi} and P_{Bo} , respectively) and dialysate compartment side (P_{Di} and P_{Do} , respectively). (B) TMP calculated with TMP2, TMP3 and TMP4. (C) Difference between TMP estimations showing the influence of successively adding a third (TMP3 - TMP2, filled diamonds) and fourth (TMP4 - TMP3, open diamonds) measuring point.

Figure 3 shows the pressure recordings of three treatments representative of HD, HCV-HDF at cK_{D-UF} max and HCV-HDF at maximum convection flow in the same patient. It can be observed that P_{Bi} (red curve, Figure 3) is the parameter submitted to more variations during the treatment procedure. It is quite stable in dialysis, increases in HCV-HDF at cK_{D-UF} max and increases even more with HCV-HDF at Q_{UF} max, surpassing 600 mmHg (limit given in the manufacturer information for use of dialysers used in this study). These modifications in P_{Bi} are reflected by parallel changes in TMP3 (green curve, Figure 3). In HCV-HDF at Q_{UF} max, TMP3 reached the limit level of 300 mmHg, forcing decrease of the infusion rate, towards the last third of the treatment time (T_{modif}). In contrast, TMP2 did not show the variations occurring in the dialyser and remained stable, well below 300 mmHg. This reveals that safety limits do not apply in a similar manner to a system calculating the TMP2 or TMP3 and it does not render secure the system when applied to dialysis monitors calculating TMP from two pressure measurements (P_{Bo} and P_{Do}).

In Figure 4, the pressure measured at the B_i and B_o at the beginning of the session (T_{start}), and either at the moment that the infusion flow was reduced or at the end (T_{modif} or end) for the three treatment conditions (upper panels). In both HCV-HDF treatments, P_{Bo} remained stable over the session. In HD, P_{Bi} was stable during the session. In HDF-HCV with convection flow at cK_{D-UF} max, P_{Bi} increased during the session, and in HCV-HDF with maximal convection flow, P_{Bi} further increased during treatment. The distributions of TMP2 and TMP3 values at the beginning and at end of the session are plotted for the nine patients. In HD treatments, the TMP calculated from two or three sensors remained relatively stable throughout the treatment (Figure 4, left panel). In the case of HCV-HDF at cK_{D-UF} max, TMP2 and TMP3 were greater and increased during session (Figure 4, central panel). On average, TMP3 was 3.7 ± 0.2 times the value of TMP2 for the same session. There were three reductions in ultrafiltration rates due to TMP alarms ($TMP3 > 300$ mmHg) over 27 sessions. In HCV-HDF with Q_{UF} max, TMP2 and TMP3 increased further during the sessions (Figure 4, right panel). The mean difference between TMP3 and TMP2 was 148 ± 5 mmHg (range 74–247), and TMP3 was on average 2.8 ± 0.1 times the value of TMP2. There were ultrafiltration reductions due to TMP3 reaching the alarm threshold of 300 mmHg in 21 out of 26 sessions.

Pitfalls in TMP calculation with two sensors

Figure 5 presents two examples where TMP2 overlooks a problem occurring at the blood side during the dialysis procedure and shows a decrease in TMP2, while TMP3 increased. In the left panel, Figure 5 displays the recordings of an HD treatment. A marked increase in pressure at the B_i was observed for an unexpected reason (very likely clotting of the fibres) after ~150 min from session initiation. The increase in hydrostatic pressure at the blood side translates into an increase in TMP3 (green curve), whereas TMP2 displayed an artefactual decrease.

In the right panel, Figure 5 presents an example of HCV-HDF in which convection had to be reduced during the treatment procedure due to TMP3 reaching the safety limit 300 mmHg. A further increase in TMP3 was observed after resuming with a lower convection flow and was associated with a marked increase in pressure measured at the B_i , reaching values over the advised limit of use given by the manufacturer of 600 mmHg. TMP2 values (yellow curve) were much lower than TMP3 values and TMP2 variations did not reflect the changes in pressure occurring in the dialyser. The pressure changes that should trigger nurse interventions were overlooked when monitoring TMP2.

DISCUSSION

TMP was the main parameter that allowed the pioneers in dialysis to control ultrafiltration and thereby weight loss and extracellular volume. With the advent of ultrafiltration controllers [13], weight loss was accurately driven by automatic setting of TMP by dialysis monitors. TMP turned into an informative value and lost its protagonism. Subsequently, with the introduction and spread of high permeability dialysers and of the use of convective techniques, TMP regained interest. Among other things, properly assessing TMP has allowed identification of the fact that the global ultrafiltration coefficient of a dialysis system is not constant, but follows a parabolic function when convection increases [6].

It is known that TMP varies greatly along the fibres of the dialyser [14]. However, in practice, it is not possible to measure

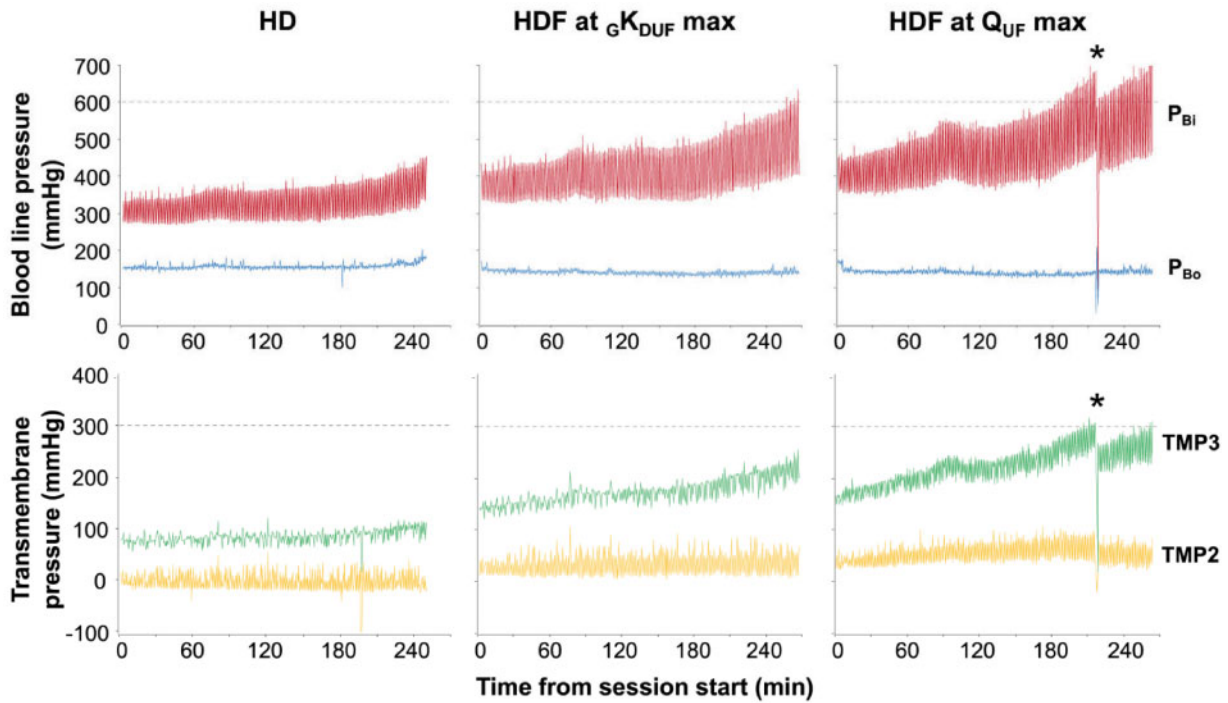

FIGURE 3: Pressure readings during dialysis treatments with different convection flows. Illustrative examples of three treatments performed in HD (left panels), high convection HDF at ${}_G K_{DUF} \text{ max}$ (central panels) or at maximum possible convection ($Q_{UF} \text{ max}$, right panels) in the same patient. The continuous recordings of pressures measured at the B_i and B_o (top panels) and TMP calculated based upon 2 or 3 measurement points (TMP2 and TMP3, lower panels) are displayed. Asterisks indicate infusion modification due to TMP alarms.

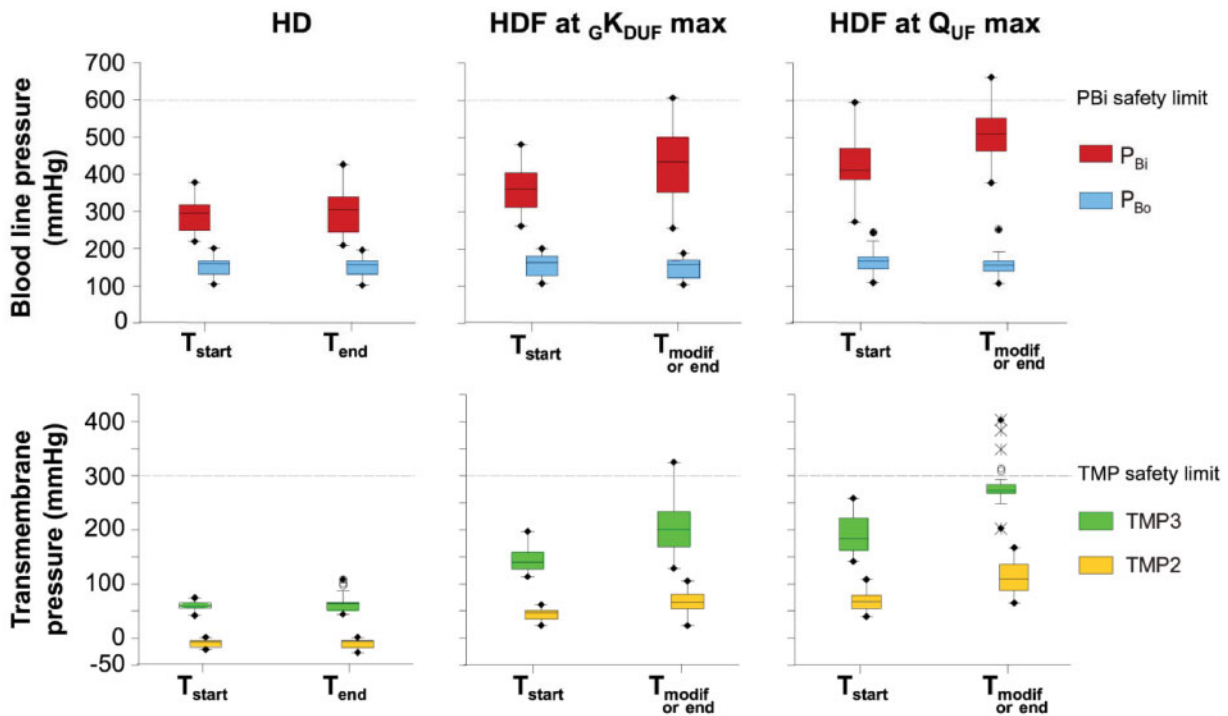

FIGURE 4: Pressure readings at two time points of dialysis treatments performed with different convection flows. Distribution of blood line pressures (top panels) and TMP (lower panels) observed in 79 treatments from 9 patients in HD (left panels), high convection HDF at ${}_G K_{DUF} \text{ max}$ (central panels) or at maximum possible convection ($Q_{UF} \text{ max}$, right panels). Values were obtained at the start of the treatment (T_{start}) and at the end of the treatment (T_{end}) or at the moment of adapting the convection because of TMP alarms ($T_{modif \text{ or } end}$), whatever was first. Box plots display median, first and third quartile, Tukey's fences and extreme values.

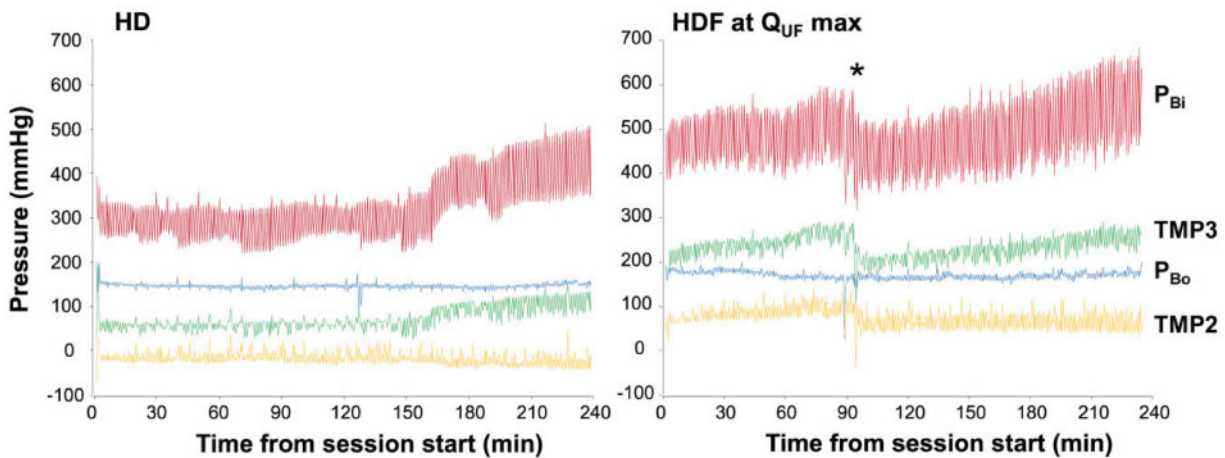

FIGURE 5: Examples of pressure variations observed during two treatments in the same patient. During an HD treatment (left panel), an unexpected pressure rise at the B_i (P_{Bi}) was observed after 150 min. TMP3 increased consequently, while TMP2 tended to slowly decrease regardless pressure variations in the blood compartment. In a high convection HDF performed at the maximum convection flow (Q_{UF} max, right panel), TMP2 and TMP3 initially followed the changes in P_{Bi} until TMP3 reached 300 mmHg and infusion had to be turned down (asterisks, infusion modification). After this point, only TMP3 followed P_{Bi} variations, while TMP2 remained constant, regardless of the variations observed in the blood compartment.

the pressure of the fibres within the dialyser and external pressure sensors located outside the dialyser are used instead. To estimate an average TMP value, dialysis machines are equipped with two, three or four pressure sensors measuring pressures at the inlet and outlet of the dialyser, at both the blood and dialysate sides. The present work was performed to evaluate the influence of TMP calculations using two and three pressure measurements on its absolute value and on its variations during sessions in the clinical situation of post-dilutional HCV-HDF. Almost no information is available on these aspects, and the rare criteria included in dialysis guidelines are not adequately described or sustained by solid data. Our study provides information on the direct effects of convection on the pressures at the dialysate and blood sides, on the resulting TMP value. It also provides a description of longitudinal changes in pressure observed throughout the treatment, and how they are induced by convection.

When performing HD without added convection, the pressures of the system remain particularly stable. When convection is added, the pressures change during the procedure and the greatest changes are observed at the blood side at the entrance of the dialyser: pressure increases in a proportional manner to the rate of convection Q_{UF} . Since the pressure at the outlet at the blood side of the dialyser remains constant during dialysis, we observe an increase in the pressure drop in the blood compartment of the dialyser. Therefore, any method to assess the pressures in the dialysis system performing HCV-HDF that does not take into account the pressure values at the B_i of the dialyser is not accurate and does not reflect the phenomena occurring inside the dialyser. This is the case when calculating TMP from only two points (P_{Bo} and P_{Do}). Since the blood pressure variations occurring during dialysis are overlooked, TMP2 should not be used to monitor a dialysis system performing HCV-HDF. Only machines performing at least a three-point TMP measurement including the B_i site should be used to monitor the dialysis systems, particularly in HCV-HDF.

Is it necessary to monitor the four points? Our preliminary study shows that TMP3 and TMP4 follow the same pattern and that the difference between the two is relatively constant. The value of this difference is the result of adding the readings from

the dialysate inlet into the formula (P_{Di} will be averaged with the P_{Do} value). In our study, this value was further increased by the location of the sensor on the dialysis machine, situated at a distance of the entrance of the dialyser. The pressure drop in the dialysate compartment is stable during the dialysis treatment, relatively independent of the convection rate and available from manufacturer documentations. In consequence, measuring the pressure at the dialysate inlet of the dialyser is not mandatory. However, should the reading of the pressure at the dialysate inlet be incorporated in the formula, it has to be corrected by the pressure drop before reaching the dialyser. Otherwise, using the crude value given by the sensor would artefactually decrease the estimated TMP4.

The relevance of our observations is supported by the tendency to advise and spread the use of HCV-HDF based upon most of the recent studies in dialysis patients [1–4], whereas the knowledge on the behaviour of the filtrating system under HCV-HDF is rather scant. Our data show precisely that in HCV-HDF, considerable modifications in TMP occur, and more particularly when convection rates overpass gK_{D-UF} max.

Secondly, we aim to increase safety and want to avoid problems occurring during treatment. Focussing on the blood side of the extracorporeal circuit, the pressure measured in the blood outlet reflects the return or venous pressure. Therefore, any sudden changes in P_{Bo} require immediate attention to the needle and blood access. The pressure at the B_i (P_{Bi}) reflects changes on the resistance to flow between the blood pump and the entrance of the dialyser. Therefore, with constant blood and convection flows, a sudden increase in P_{Bi} may be due to a decrease in effective dialysate surface or an increase in blood viscosity, both markers of initiated or premonitory of clotting in the dialyser fibres, respectively [15]. As we have shown in Figure 5, left panel, this complication may be prevented if monitored TMP is calculated using three or four pressure points, as they include the pressure measured at the P_{Bi} . TMP3 and TMP4 will warn about a sudden increase in pressure at the B_i and preventive measures may be implemented, whereas TMP2 will not. Some machines presently available still use a TMP2 monitoring though.

Furthermore, with the advent of the HCV-HDF, the knowledge on the pressure changes in the system will help in establishing safety limits for this type of treatment. The ERBP has emitted an advice limiting the TMP to 300 mmHg [9]. However, our data clearly show that any given TMP limit should be associated to a type of TMP calculation. We have seen that 300 mmHg of TMP3 is already associated with increases in pressure at the B_i that may be beyond those advised by the manufacturer and that the use of TMP2 overlooks them. We think it may also be appropriate to monitor pressure at the B_i and propose to set a limit to be the dialyser manufacturer limit.

In summary, our study provides new information on the behaviour of dialysis systems, particularly relevant when performing HCV-HDF, which may help to establish pressure safety. We show that a strong discrepancy exists across TMP calculations, whereas appropriately monitoring pressures should be sought.

ACKNOWLEDGEMENTS

P.B., J.J. and À.A. are members of the European Uraemic Toxin (EUTox) working group of the European Society of Artificial Organs, endorsed by the European Renal Association-European Dialysis and Transplant Association.

CONFLICT OF INTEREST STATEMENT

A.F., N.G., F.D. and À.A. are employees of RD—Néphrologie, owner of the patent protecting the exploitation rights of the patents EP2362790, JP5587891 and US8298427. The results presented in this article have not been published previously in whole or part, except in abstract format.

REFERENCES

1. Maduell F, Moreso F, Pons M et al. High-efficiency postdilution online hemodiafiltration reduces all-cause mortality in hemodialysis patients. *J Am Soc Nephrol* 2013; 24: 487–497
2. Ok E, Asci G, Toz H et al. Mortality and cardiovascular events in online haemodiafiltration (OL-HDF) compared with high-flux dialysis: results from the Turkish OL-HDF Study. *Nephrol Dial Transplant* 2013; 28: 192–202
3. Grooteman MP, van den Dorpel MA, Bots ML et al. Effect of online hemodiafiltration on all-cause mortality and cardiovascular outcomes. *J Am Soc Nephrol* 2012; 23: 1087–1096
4. Maduell F, Varas J, Ramos R et al. Hemodiafiltration reduces all-cause and cardiovascular mortality in incident hemodialysis patients: a propensity-matched cohort study. *Am J Nephrol* 2017; 46: 288–297
5. Locatelli F, Karaboyas A, Pisoni RL et al. Mortality risk in patients on hemodiafiltration versus hemodialysis: a ‘real-world’ comparison from the DOPPS. *Nephrol Dial Transplant* 2018; 33: 683–689
6. Ficheux A, Kerr PG, Brunet P et al. The ultrafiltration coefficient of a dialyser (KUF) is not a fixed value, and it follows a parabolic function: the new concept of KUF max. *Nephrol Dial Transplant* 2011; 26: 636–640
7. Ficheux A, Ronco C, Brunet P et al. The ultrafiltration coefficient: this old ‘grand inconnu’ in dialysis. *Nephrol Dial Transplant* 2015; 30: 204–208
8. Penne EL, van der Weerd NC, Bots ML et al. Patient- and treatment-related determinants of convective volume in post-dilution haemodiafiltration in clinical practice. *Nephrol Dial Transplant* 2009; 24: 3493–3499
9. Tattersall J, Martin-Malo A, Pedrini L et al. EBPG guideline on dialysis strategies. *Nephrol Dial Transplant* 2007; 22 (Suppl 2): ii5–ii21
10. Merlo S, Donadey A, Coevoet B et al. Générateurs d'hémodialyse: état du marché français. *IRBM* 2007; 28: 150–168
11. Ficheux A, Gayrard N, Durantont F et al. A reliable method to assess the water permeability of a dialysis system: the global ultrafiltration coefficient. *Nephrol Dial Transplant* 2017; 32: 364–370
12. Gayrard N, Ficheux A, Durantont F et al. Consequences of increasing convection onto patient care and protein removal in hemodialysis. Mischak H, editor. *PLoS One* 2017; 12: e0171179
13. Kozlov JG, Khaitlin AE, Lisitsina K (inventors, assignee). *Device for Preparation of a Dialysing Solution*. US patent 3804107, 1974
14. Ronco C, Brendolan A, Feriani M et al. A new scintigraphic method to characterize ultrafiltration in hollow fiber dialyzers. *Kidney Int* 1992; 41: 1383–1393
15. Mitra S, Mitsides N. Technical aspects of hemodialysis. In Magee CC, Tucker JK, Singh AK (eds). *Core Concepts in Dialysis and Continuous Therapies*. Boston, MA: Springer US, 2016, pp. 15–26. Available from: http://link.springer.com/10.1007/978-1-4899-7657-4_2